

---

# Citadel Patient Therapy System

## Instructions for Use

**ARJOHUNTLEIGH**  
GETINGE GROUP



Design Policy and Copyright

® and ™ are trademarks belonging to the ArjoHuntleigh group of companies unless otherwise stated.

© ArjoHuntleigh 2017

As our policy is one of continuous improvement, we reserve the right to modify designs without prior notice. The content of this publication may not be copied either wholly or in part without the consent of ArjoHuntleigh.

# Table of Contents

General Warnings.....	5
• Safety Information .....	6
Introduction.....	8
Clinical Applications.....	8
• Intended Use .....	8
• Indications .....	9
• Contraindications .....	9
• General Product Information .....	9
• Risks and Precautions.....	9
• Precautions.....	10
Installation .....	11
• Attach Air Mattress Control Unit .....	11
• Attach Integrated Air Mattress .....	14
• Testing .....	17
• Mattress Length Adjustment .....	18
• To extend the deck .....	18
• Air Mattress Length Extension.....	19
• X-Ray Sleeve.....	19
Control Panel.....	20
• <i>Citadel</i> Patient Therapy System Control Panel .....	20
• Air Pressure Adjustment Controls.....	21
• Height / Weight Presets.....	21
• Pressure Zone Indicators .....	22
• Turning.....	22
• Continuous Patient Turn Hold Time Button (optional configuration).....	23
• Pulsation / Alternating Pressure Therapy (optional configuration).....	23
Patient Placement / Transfer .....	24
• Preparation for Patient Placement / Transfer .....	24
• Patient Placement .....	24
• Patient Transfer from the <i>Citadel</i> Patient Therapy System.....	24
• Patient Transport .....	25
Nursing Care .....	26
• CPR .....	26
• Alarms .....	26
• Audible Tone Indicators .....	28
• Patient Bathing .....	28
Care and Cleaning.....	29
• General Recommendations .....	29
• Decontamination.....	29
• Cleaning .....	29
• Disinfecting .....	30
• Cleaning the <i>Citadel</i> Patient Therapy System While in Use.....	30

•Cleaning and Maintenance Between Patients.....	31
•Care And Cleaning Mattress Cover Fabrics .....	31
Operating Instructions .....	33
•Normal Therapy Mode .....	33
•Nurse Assist Functions .....	33
•Therapies.....	34
•Alternating Pressure / Pulsation .....	34
•Power Off <i>Citadel</i> / Patient Therapy System .....	35
Warranty and Service .....	36
Electromagnetic Compability (EMC).....	37
Troubleshooting .....	40
Explanation of Symbols Used.....	41
Specifications .....	43

## GENERAL WARNINGS

The following warnings should be considered prior to using this product:



*Prior to activating any positioning function assess the security of all patient support lines and tubes to accommodate the desired angle of articulation and minimize the risk of binding, disconnecting or dislodging. Tubes and lines should always have sufficient slack for articulation and patient movement.*

*Before patient transfer to or from the Citadel Bed Frame System, all brakes should be engaged.*

*Always unplug the Citadel Bed Frame System from wall outlet before cleaning. Failure to do so could result in equipment damage and / or electric shock.*

*Assembly, operations, extensions, re-adjustments, modifications, technical maintenance or repairs must be performed by qualified personnel authorized by ArjoHuntleigh. Contact ArjoHuntleigh for information regarding maintenance and repair.*

*All accessories added to the system reduce the safe working load of the frame by the same amount.*

*If the power supply cord or plug is damaged, the cord must be replaced.*

*Make sure the power supply cord is not stretched, kinked or crushed.*

*Make sure the power supply cord does not become entangled with moving parts of the bed or trapped between the bed frame and head board.*

*Presets are provided for reference only. Individual patient needs should be assessed and the pressure settings should be adjusted to meet each patient's individual needs.*

*Monitor patient airway and position during inflation / deflation of mattress. Ensure patient and any patient support lines are properly supported at all times.*

*Rotation therapies are not available when fowler angle is above 30° or any side rail is down. It is recommended that turning only be initiated when bed is level and thigh and calf sections are down.*

*Do not allow fluid to penetrate the Citadel Patient Therapy System control panels.*

## Safety Information

**General Protocols** – Follow all applicable safety rules and institution protocols concerning patient and caregiver safety.

**Brakes** – Set all caster brakes before transferring patient.

**Bed Height** – To minimize risk of falls or injury, the bed should always be in the lowest practical position when the patient is unattended.

**Fluids** – Avoid spilling fluids on unit controls. If spills do occur, unplug unit, clean fluid from unit, wearing rubber gloves to avoid any possibility of shock. Once fluid is removed, check operation of components in area of spill.



**Fluids remaining on controls can cause corrosion, which may cause components to fail or to operate erratically, possibly producing hazards for patient and staff.**

**Oxygen Use** - Ensure that the unit is not contained in an oxygen enriched environment. Possible fire hazard when bed is used with oxygen administering equipment other than the nasal prongs, mask or half bed length tent type. Oxygen tent should not extend below mattress support level.

**Lock-Outs** – Lock-outs for air mattress system functions should be used at staff's discretion to ensure against unintentional operation of *Citadel* Patient Therapy System.

**Disposal** – At the end of useful life, dispose of waste according to local requirements or contact the manufacturer for advice. There may be special requirements for disposal of batteries, leaded foam and / or angle sensors (if present in this product). Improper disposal of any component may result in regulatory non-compliance.

**Moving Parts** - Keep all equipment, tubes and lines, loose clothing, hair and parts of the body away from moving parts and pinch points.

**Patient Entrance / Exit** – Caregiver should always aid patient in exiting the bed. Make sure a capable patient knows how to get out of bed safely (and, if necessary, how to release the side rails) in case of fire or other emergency.

**Side Rails / Patient Restraints** - Whether and how to use side rails or restraints is a decision that should be based on each patient's needs and should be made by the patient and the patient's family, physician and caregivers, with facility protocols in mind. Caregivers should assess risks and benefits of side rail / restraint use (including entrapment and patient falls from bed) in conjunction with individual patient needs, and should discuss use or non-use with patient and / or family. Consider not only the clinical and other needs of the patient but also the risks of fatal or serious injury from falling out of bed and from patient entrapment in or around the side rails, restraints or other accessories. In the US, for a description of entrapment hazards, vulnerable patient profile and guidance to further reduce entrapment risks, refer to FDA's Hospital Bed System Dimensional and Assessment Guidance To Reduce Entrapment. Outside the US, consult the local Competent Authority or Government Agency for Medical Device Safety for specific local

guidance. Consult a caregiver and carefully consider the use of bolsters, positioning aids or floor pads, especially with confused, restless or agitated patients. It is recommended that side rails (if used) be locked in the full upright position when the patient is unattended. Make sure a capable patient knows how to get out of bed safely (and, if necessary, how to release the side rails) in case of fire or other emergency. Monitor patients frequently to guard against patient entrapment.

**Skin Care** – Monitor skin conditions regularly and consider adjunct or alternative therapies for high acuity patients. Give extra attention to skin over any raised side bolster and to any other possible pressure points and locations where moisture or incontinence may occur or collect. Early intervention may be essential to preventing skin breakdown.

**Maximum Recommended Patient Weight** - Total patient weight capacity should not exceed 227 kg (500 lb). The use of accessories on the bed may decrease the patient weight capacity of the bed. Contact ArjoHuntleigh Customer Service for questions concerning the use of accessories and see the Questions and Information section of this guide for contact information.

**I.V. and Drainage Tubes** – Prior to activating any positioning or rotation function assess the security of all invasive lines and tubes to accommodate the desired angle of articulation and minimize the risk of binding, disconnecting or dislodging. Tubes and lines should always have sufficient slack for articulation and patient movement.

**Turning - CAUTION:** Prior to engaging any mattress turn feature, ensure that all side rails are fully engaged in their full upright and locked position.

# INTRODUCTION

These instructions contain information for the installation, use and maintenance of the ArjoHuntleigh Citadel™ Patient Therapy System. The *Citadel* Patient Therapy System provides an integrated pressure redistribution surface for the Citadel™ Bed Frame System. The *Citadel* Patient Therapy System can only be used with the *Citadel* Bed Frame System.

All *Citadel* Patient Therapy Systems (C100 and C200 models) have the following standard features:

- Four-zone pressure adjustment
- Patient height and weight presets
- Patient turn
- Head deflate
- Seat deflate
- Firm mattress
- Patient transport mode

The following features are additionally included in the C200 model:

- Continuous patient turn
- Alternating pressure
- Pulsation

# CLINICAL APPLICATIONS

## Intended Use

The *Citadel* Patient Therapy System is intended for the acute and post-acute care environments. It is not intended for use in the homecare environment.

When used with the *Citadel* Bed Frame System, the *Citadel* Patient Therapy System is intended for the prevention and treatment of pressure ulcers, to treat burns and to aid circulation.

The addition of Skin IQ™ Family (*Skin IQ* Family) can aid in the prevention and treatment of skin breakdown and pressure ulcers (stages I-IV)<sup>1</sup> for patients who require microclimate management of the skin.

---

<sup>1</sup> National Pressure Ulcer Advisory Panel, European Pressure Ulcer Advisory Panel and Pan Pacific Pressure Injury Alliance. Prevention and Treatment of Pressure Ulcers: Quick Reference Guide. Emily Haesler (Ed.) Cambridge Media: Perth, Australia; 2014.



## Indications

Patient conditions for which the *Citadel* Patient Therapy System is indicated are:

- Prevention and treatment of pressure ulcers (stages I-IV) in high-risk patients.

## Contraindications

Patient conditions for which the *Citadel* Patient Therapy System is contraindicated are:

- Cervical traction
- Unstable vertebral fracture
- Patient weight >227 kg (500 lb)

## General Product Information

*Citadel* Bed Frame System safe working load (SWL).....270 kg (595 lb)

*Citadel* Patient Therapy System:

Integrated air mattress and air mattress control unit.....43 kg (94.5 lb)

Remaining safe working load of the bed frame .....227 kg (500 lb)

Expected Service Life.....Five years



*All accessories added to the system reduce the safe working load of the frame by the same amount.*

The recommended patient height is between 146 cm (58 in) and 190 cm (75 in). At the discretion of the caregiver, patients taller than 190 cm (75 in) may be accommodated by extending the frame and mattress. Ensure that the patient's height does not exceed the in-bed length.

## Risks and Precautions

**Patient Migration** – Specialty surfaces have different shear and support characteristics than conventional surfaces and may increase the risk of patient movement, sinking and / or migration into hazardous positions of entrapment and / or inadvertent bed exit. Monitor patients frequently to guard against patient entrapment.

**Side Rails and Restraints** – **WARNING:** Use or non-use of restraints, including side rails, can be critical to patient safety. Serious or fatal injury can result from the use (potential entrapment) or non-use (potential patient falls) of side rails or other restraints. See related Safety Information section of this guide.

**Skeletal Traction or Unstable Fracture (if not contraindicated)** – With skeletal traction, unstable pelvic fracture or any other unstable fracture (to the extent not contraindicated), maintain physician directed angle of articulation and guard against risks of patient migration or inadvertent deflation of surface.

**Electromagnetic Interference** – Although this equipment conforms with the intent of electromagnetic compatibility, all electrical equipment may produce interference. If interference is suspected, move equipment away from sensitive devices or contact the manufacturer.

**Shock Hazard** – Electrical shock hazard; do not remove electrical compartment covers. Refer to qualified service personnel.

## **Precautions**

Precautions may need to be taken when using this product with certain patient conditions, including, but not limited to:

- Hemodynamic instability
- Severe agitation
- Uncontrollable claustrophobia or fear of confinement
- Uncontrollable diarrhea
- Pregnancy
- Extensive facial trauma
- Any other unstable fracture
- ICP monitoring or intracranial drainage devices

# INSTALLATION

## Attach Air Mattress Control Unit



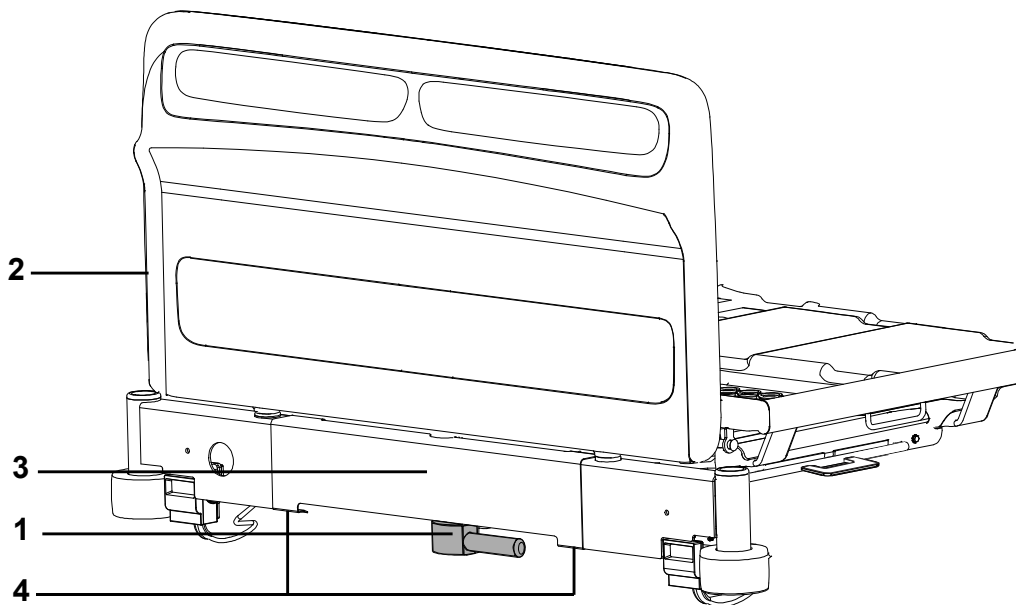
*Unit should only be installed by qualified personnel.*

*A second person may be needed for the lifting of the air mattress control unit.*

1. Ensure the *Citadel* Bed Frame System mains power is unplugged from the wall outlet.
2. Remove the existing mattress, if applicable.
3. The air mattress control unit is provided with the following items (contact ArjoHuntleigh if the items are missing or damaged):

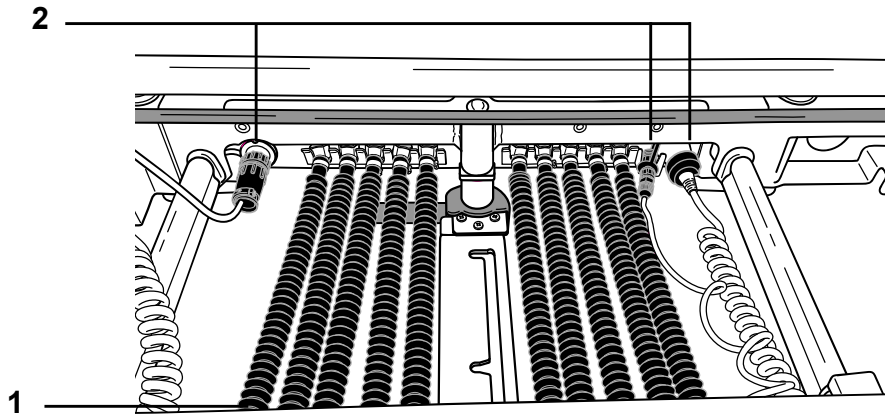
Item Description	Quantity
Air Mattress Control Unit	1
Citadel Patient Therapy System IFU	1
Citadel Patient Therapy System QRG	1
Storage Bag	1
Philips Pan Head Screws	4
Hex Head Screws	3
Grounding Screws	2

4. Pull the foot extension handle (see figure 1, item 1), slide the frame extension out (3) and remove the foot board (2).



**Figure 1: Foot board and foot extension**

5. Locate the foot extension cover plate (see figure 1, item 3), with air hoses (figure 2, item 1) and electrical connectors (2) attached, under the foot end of bed. Disconnect the air hoses and electrical connectors from the foot extension cover plate.



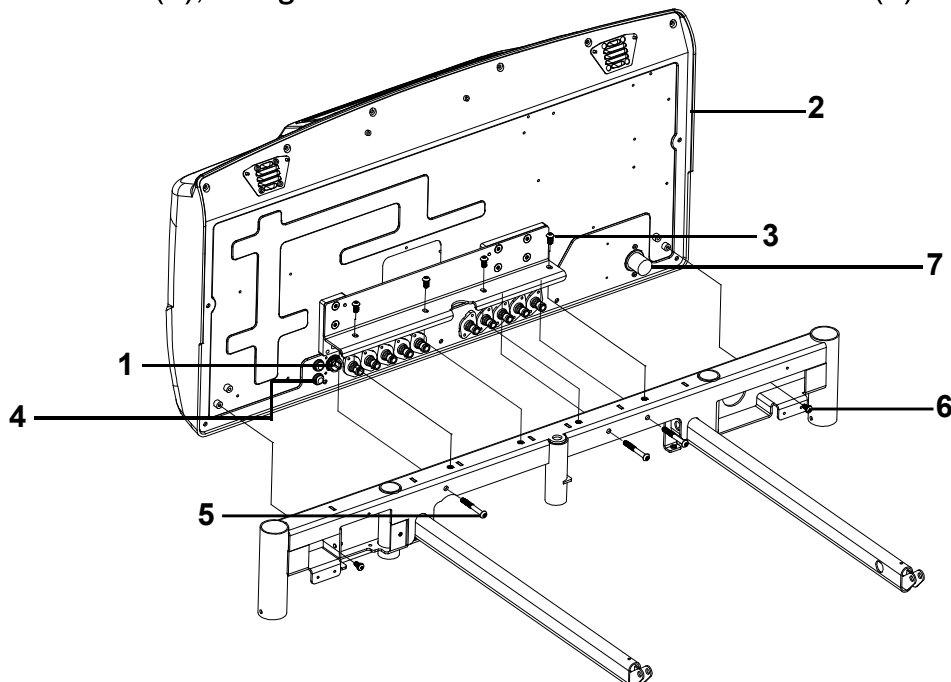
**Figure 2: Foot extension cover plate with air hoses and electrical connections**

6. Remove cover plate by unscrewing two Philips Pan head screws (see figure 1, item 4) on the underside of the cover. Place cover plate and hardware in storage bag in case air mattress control unit is removed later. The foot extension cover plate will need to be reinstalled to secure air hoses and electrical connectors.



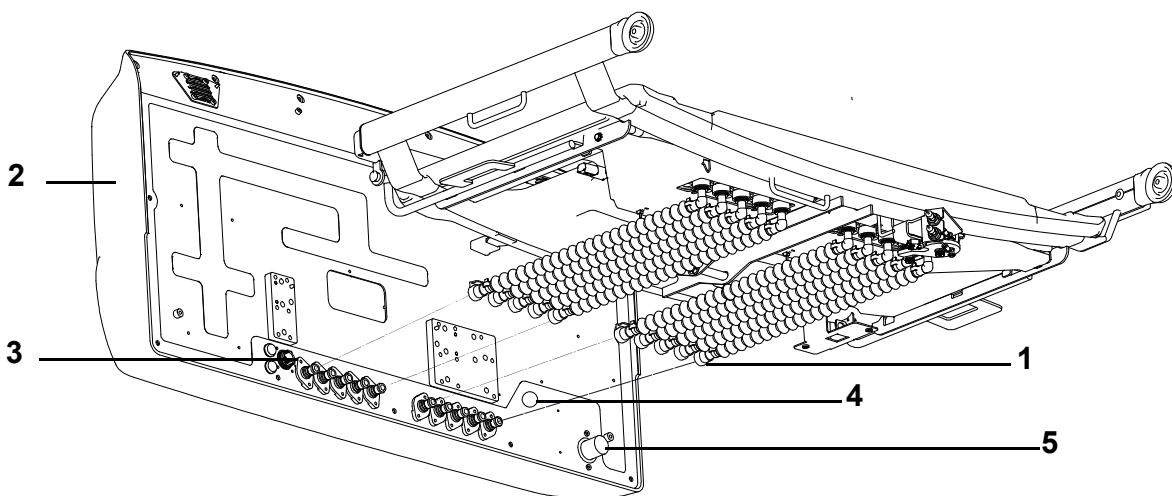
*Electrical connectors must be connected to the air mattress control unit when installed, or attached to the foot extension cover plate if the air mattress control unit is not installed.*

7. If not already installed, Install the air mattress control unit mounting bracket (see figure 3, item 1) to the back of the air mattress control unit (2), using the six hex head flush mount screws (4).



**Figure 3: Air mattress control unit and mounting bracket**

8. Lift air mattress control unit and slightly tilt the air mattress control unit forward and then gently lower it onto the frame. Carefully align holes on top of mounting bracket with holes on frame. As air mattress control unit sits onto the frame, gently tilt to full upright position while observing that the communication connector (see figure 3, item 7) on control unit aligns to hole in frame. Be careful not to damage the air connectors.
9. Gently slide air mattress control unit from side to side to align holes on top and on front of mounting bracket with holes on extension frame.
10. Loosely install four Philips Pan Head screws through the top of mounting bracket (figure 3, item 3) (Do not tighten at this time).
11. Install three hex socket screws through the holes on the front of mounting bracket. These pass through the mounting bracket / frame extension and screw into the mattress control unit. Torque screws to 10 Nm.
12. Now tighten the four Philips Pan head screws started earlier on top of the mounting bracket. Torque screws to 10 Nm.
13. Install two pan-head Philips screws (figure 3, item 6), on the back of the control unit, RH / LH lower corners. Torque screws to 10 Nm.
14. Connect air hoses (figure 4, item 1) to air mattress control unit (2); ensure O-rings are on connection ports. Air hoses attach straight across from the dump valve assembly over the foot extension crossbar to the air mattress control unit in order from left to right / right to left. A distinct click will be heard when the air connectors are fully attached.

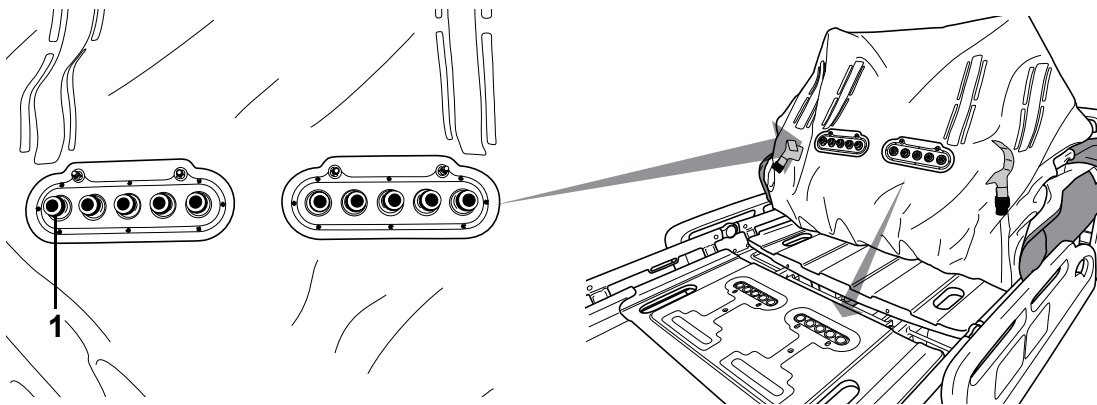


**Figure 4: Connect air hoses to mattress control unit**

15. Connect AC power cable (figure 4, item 3), CPR cable (4) and communication cable (5).

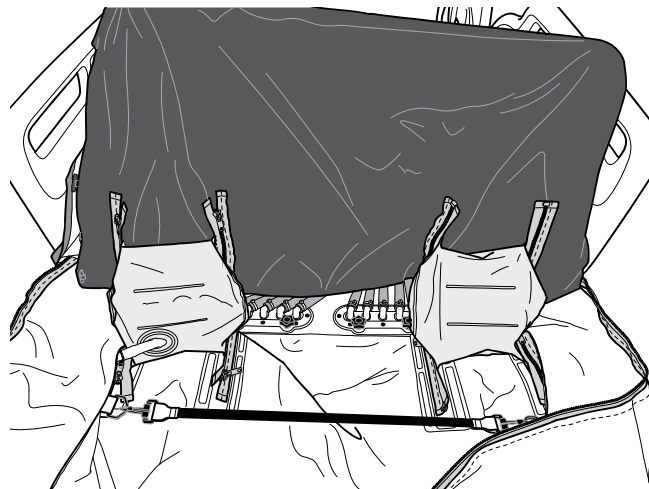
## Attach Integrated Air Mattress

1. Remove air mattress from its packaging and roll out on the bed. Notice air connectors on bottom of air mattress (figure 5). These should be placed at the foot end of the bed. Locate the dump valve / air connectors incorporated into the foot end of the air mattress support deck. Ensure all packaging materials are removed from air connectors on bottom of air mattress.
2. Unzip the bottom zipper of the air mattress and lift foot end of air mattress to access the air connectors under the air mattress cushions and mattress base.
3. Look at the air connectors under the mattress and ensure O-rings (figure 5, item 1) are in place on each connector.



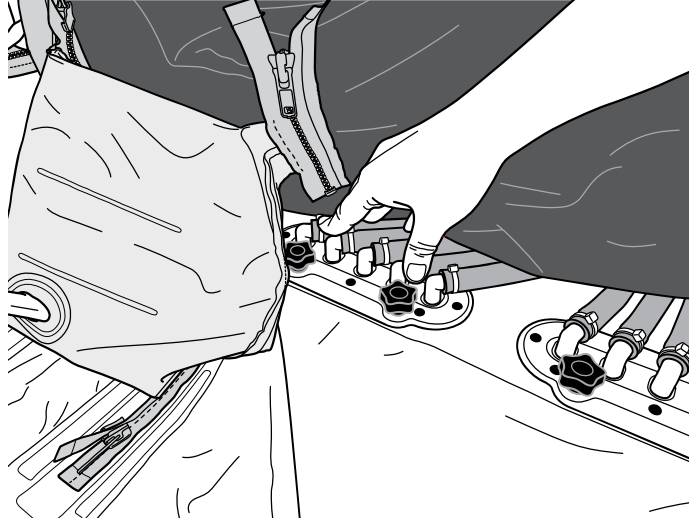
**Figure 5: Air connectors under mattress**

4. Lift cushions (figure 6) and visually guide air connectors on the air mattress into connection ports.



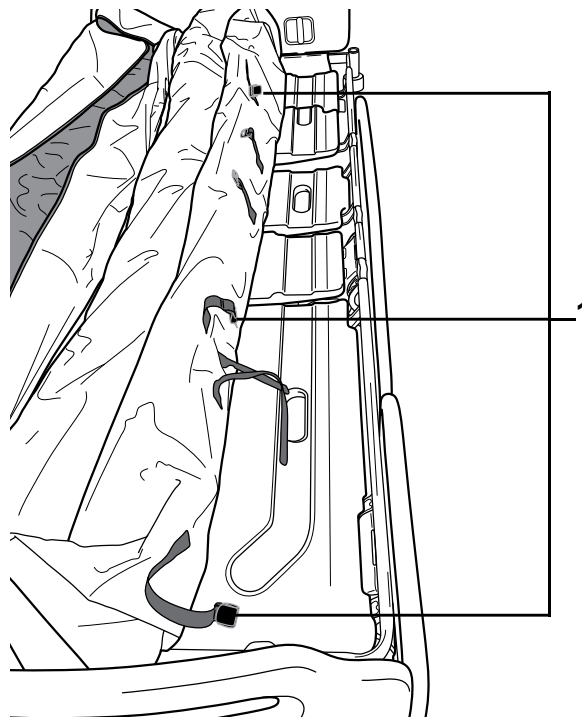
**Figure 6: Air connectors under cushion inside mattress**

5. To fully draw down and secure the air connections:
- Use a rocking motion while pressing down on the top of the connectors.
  - While firmly pressing down on the connectors, screw the knobs down until they are slightly tight.
  - Repeat steps 1 and 2 until the knobs are fully tightened. This will ensure a robust air seal.

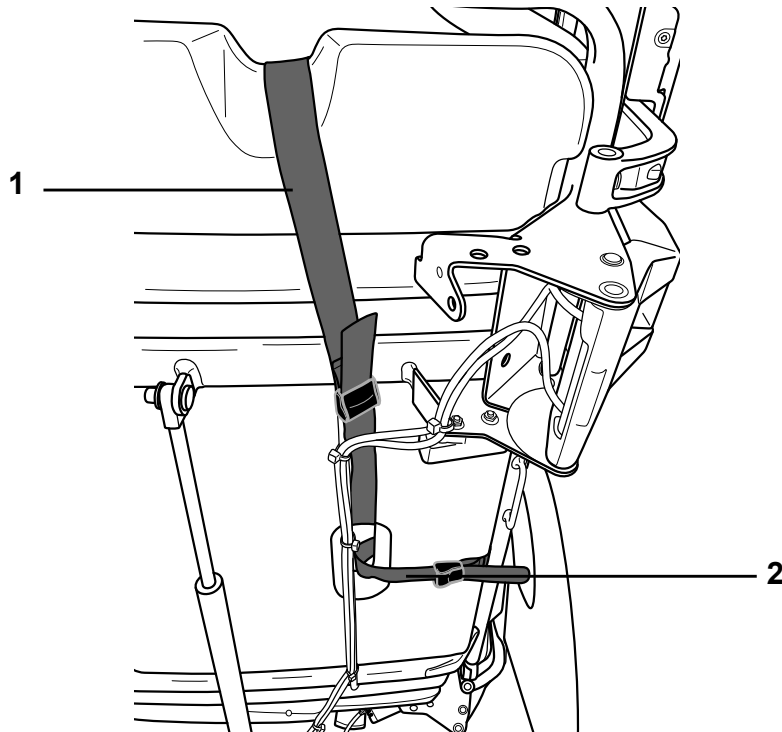


**Figure 7: Press firmly on air connectors**

6. Use mattress straps (figure 8, item 1) located on bottom of mattress to secure mattress to frame. There are three straps located on each side of the frame for a total of six straps at the head and foot ends (see figure 8). Two *Skin IQ* straps are also available. Make sure mattress is secured to an articulated section of the frame (see figure 8).



**Figure 8: Mattress straps head to foot view**



**Figure 9: Attach mattress straps to articulated section of frame**

7. Place strap 1 and strap 2 through the opening in the backrest deck section and draw together as show in Figure 9. Secure them together with their buckles. Wrap both ends of straps around the frame cross-member and secure with the buckle. Repeat for other side of the mattress.
8. Replace foot board.
9. Before using the mattress system, test the product using the procedure listed below.



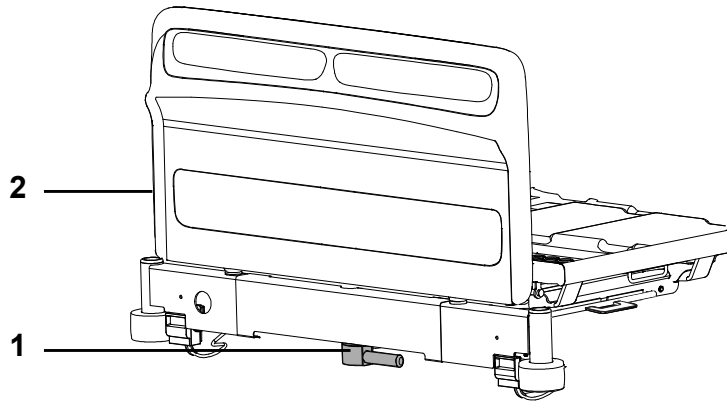
## Testing

Prior to patient placement, the following test procedures should be performed to make sure air mattress control unit and air mattress installation are complete:

1. Plug the power cord into power outlet.
2. Turn the air mattress control unit on by pressing and holding the power button on the control panel and allow the mattress to inflate. The mattress should fully inflate in no more than three minutes. The mattress section LEDs on the control unit panel will blink whilst the mattress inflates. When the mattress is fully inflated the LEDs will stop blinking.
3. If the mattress does not inflate or an air leak is heard, check that the CPR valves are closed. Check for a leak at the mattress to frame connection point. Refer to Attach Integrated Air Mattress Section, figure 7, to tighten this connection.
4. At one of the bed control panels, raise the backrest angle to above 30° as indicated on the weigh panel display. Verify that the >30° indicator is lit on the Air Mattress Control unit.
5. Raise all of the side rails. Put the head right side rail into the lowered position and verify that the appropriate side rail down indicator is lit on the Air Mattress Control unit. Raise the side rail. Repeat this procedure for the other three side rails. Lower backrest to approximately 15°.
6. Press the patient turn right button. Wait a few seconds to verify the mattress has begun to turn. Put one of the right side rails into the lowered position and verify that the alarm is heard and the mattress starts to return to a level position. Verify the side rail down and alarm indicators are both lit and the nurse turn right indicator is blinking. Press the alarm silence button to acknowledge and clear the alarm.
7. Press and hold the CPR button on the attendant control panel. Verify that the bed deck flattens (if in an articulated position), the CPR valves open, the air mattress deflates and the Air Mattress Control unit turns off.
8. Press the power button on the Air Mattress Control Unit and allow the mattress to fill.
9. Raise backrest to approximately 15°, pull CPR handle on the side of the bed frame. Verify that the backrest flattens (if in an articulated position), the CPR valves open, the air mattress deflates and the Air Mattress Control unit turns off.

## Mattress Length Adjustment

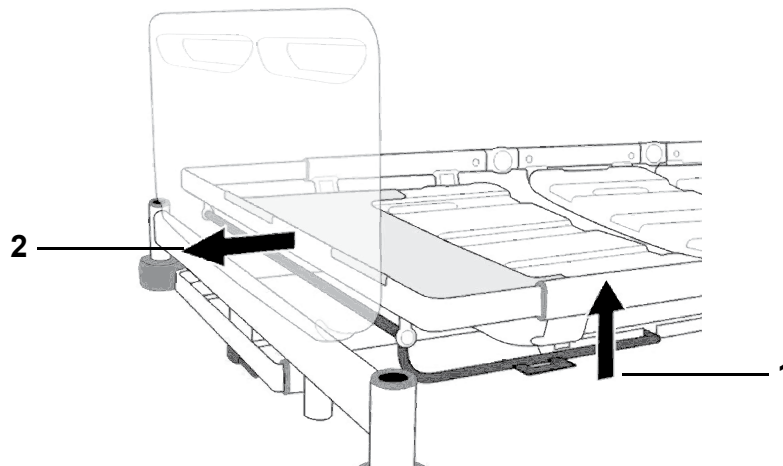
1. To extend the bed frame: rotate the blue extension locking handle (1) located under the foot end of bed and pull out the bed frame (2) to the required position and release the handle.



**Figure 10: Extending the bed frame**

### To extend the deck:

2. Lift the blue extension locking handles on either side of the bed (1) pull out the deck (2) to the required position and release the handles.



**Figure 11: Extending the deck**

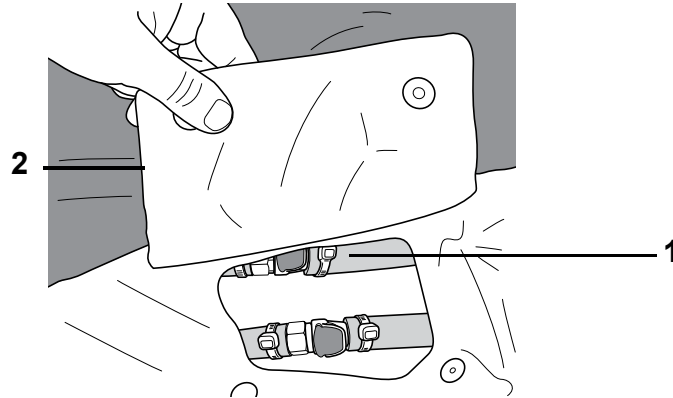


*After extending the deck make sure the calf extension sheet is clipped over the end of the deck frame.*

3. To shorten the bed: Reverse the above procedure.

## Air Mattress Length Extension

1. Locate the extension flap at the patient's right foot end of the mattress. Unsnap and lift the flap (figure 12, item 2) to access the two sets of connectors (1) on the air mattress.



**Figure 12: Extension flap**

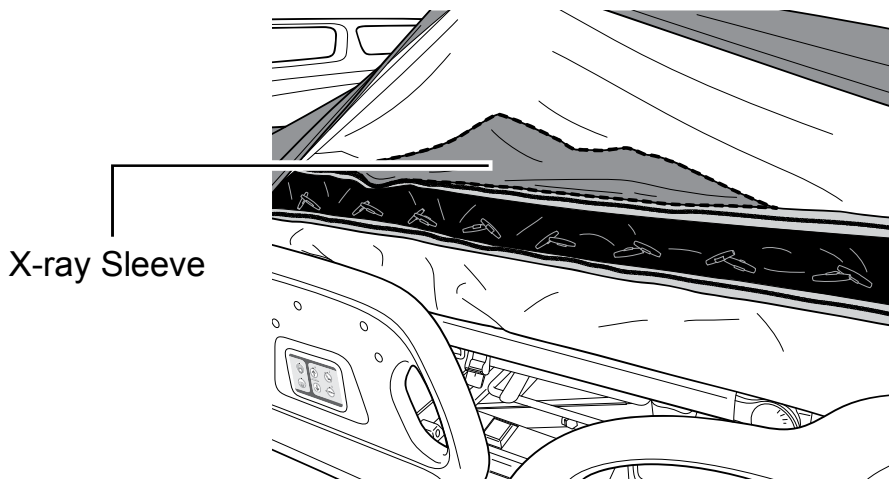
2. Connect the connectors to inflate the extension cushion in the leg section. This will lengthen the mattress.

## X-Ray Sleeve

An X-ray sleeve is provided in the mattress in order to place an X-ray cartridge under the patient without having to take the patient off of the mattress.

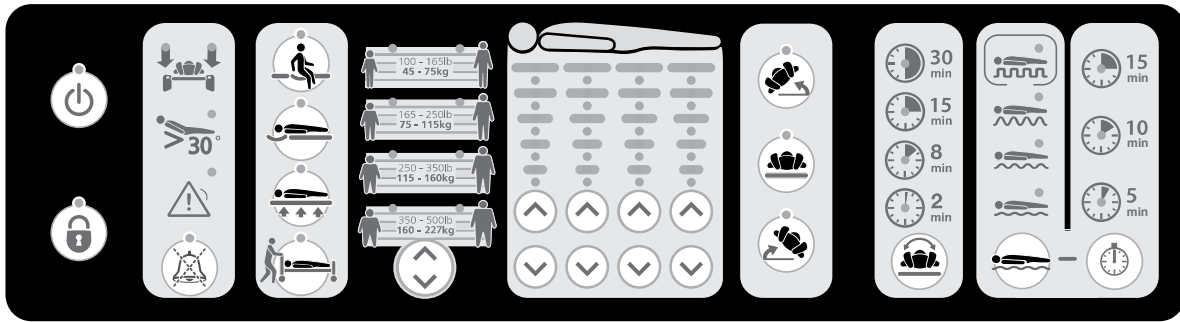
The sleeve is located at the head end at the shoulder and chest section on the patient's right side. Lower the side rails and lift the outer flap of the mattress to access the sleeve located **above the zipper** on the mattress.

**i** It is not necessary to unzip the mattress to access the X-ray sleeve.



**Figure 13: X-ray sleeve**

# CONTROL PANEL



## Citadel Patient Therapy System Control Panel



**Power On / Off Button** - Press and hold for two seconds to turn *Citadel Patient Therapy System* on or off. LED will light and an audible tone will sound. Bed must be plugged into AC power for control unit to turn on.



**Lock Out Button** - Press and hold for two seconds to activate or deactivate lockout of all control unit functions. Pressing the CPR button overrides all lockouts.



**Side Rail Down Indicator** - Lights up when the left or right side rails are down.



**Fowler Angle Indicator** - Lights up when fowler angle is greater than 30°.



**Alarm Indicator** - Lights up when an alarm or alarm condition exists in the *Citadel Patient Therapy System*. The icon will turn off when all alarm conditions are no longer present and the alarm has been acknowledged by pressing the Alarm Silence / Clear Button.



**Alarm Silence / Clear Button** - Press to acknowledge an alarm. Pressing this button will clear an alarm indicator for a condition that has been resolved. If the alarm condition has not been resolved, pressing the button will mute the alarm for ten minutes. If the condition causing the alarm is not corrected within ten minutes the alarm tone will resume.



**Seat Deflate Button** - Press to activate or deactivate seat deflate. Use seat deflate to reduce the air pressure in the cushions of the body section in order to assist with patient exit and bedpan placement. An audible tone will sound to indicate when the pressure in the seat section has dropped by 50%. Periodically an audible tone will sound to remind the user that the function is still active.



**Head Deflate Button** - Press to activate or deactivate head deflate. Use head deflate to position the head lower than the body for procedures such as intubation. An audible tone will sound to indicate when the pressure in the head section has dropped by 50%. Periodically an audible tone will sound to remind the user that the function is still alive.



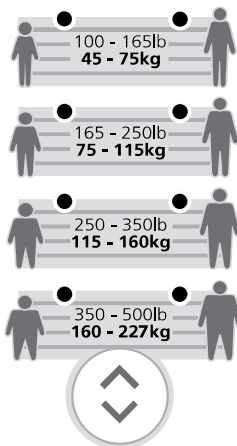
**Firm Mattress Button** - Press to activate or deactivate firm mattress function. Use firm mattress to inflate the air mattress cushions to a higher pressure, making the air mattress firmer, to facilitate actions such as patient transfer or positioning. An audible tone will sound when the function has completed. Periodically an audible tone will sound to remind the user that the function is still active. After 30 minutes the function will cancel and the system will return to the previously selected pressure setting.



**Patient Transport Button** - Press to activate or deactivate patient transport. Use patient transport to inflate the air mattress slightly above the set pressures, prior to unplugging the bed in preparation for transporting the patient in the bed. Pressing the Patient Transport Button allows for continued patient support while the system is not powered. An audible tone will sound when the function has completed. Periodically an audible tone will sound to remind the user that the function is still alive.

## Air Pressure Adjustment Controls

### Height / Weight Presets



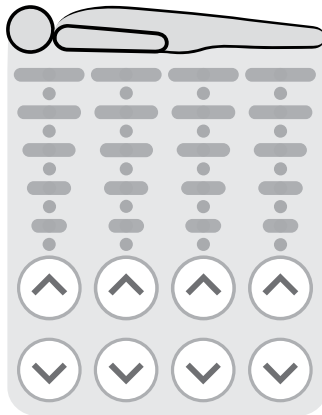
Press the height / weight preset button to select the preset that most closely corresponds to the patient body type and weight.

Pressure zone indicators will indicate pressure settings for each preset.



*Presets are provided for reference only. Individual patient needs should be assessed and the pressure settings should be adjusted to meet each patient's individual needs.*

## Pressure Zone Indicators



The pressure zone indicators will indicate the individual pressure settings for each zone.

Solid green LEDs indicate relative pressure set points for each mattress zone.

LEDs will flash when section is adjusting toward target pressure.

Each zone is independently adjustable using up and down arrows. The up arrows will increase pressure; the down arrows will decrease pressure.



*Monitor patient airway and position during inflation / deflation of mattress. Ensure patient and any patient support lines are properly supported at all times.*

## Turning



*Prior to engaging any mattress turn feature, make sure that all side rails are fully engaged in their full upright and locked position. Do not activate the turning feature on any mattress system when patient restraints are in use.*



**Patient Turn Right Button (nurse assist)** - Press to rotate the patient approximately 20° to their right. An audible tone will sound when the turn has completed.



**Patient Center Button** - Press to return patient from a turned position to flat.

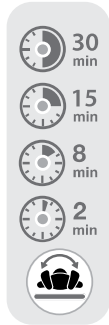


**Patient Turn Left Button (nurse assist)** - Press to rotate the patient approximately 20° to their left. An audible tone will sound when the turn has completed.



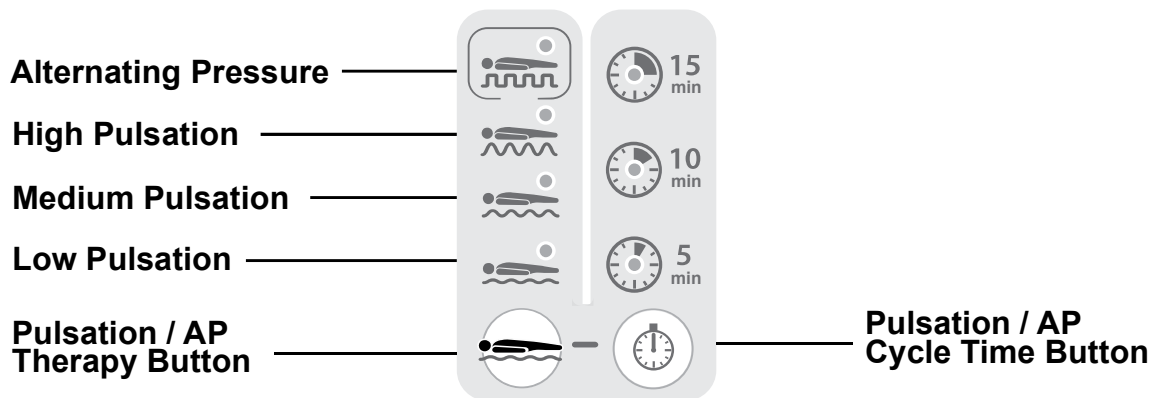
**The actual angle of rotation achieved by a patient is dependent on many factors including: patient weight, patient weight distributions, pressure settings and patient positioning on the mattress surface. 20° is the target turn angle, but will not be achieved by all patients based on the variables mentioned above.**

## Continuous Patient Turn Hold Time Button (optional configuration)



Press to initiate continuous patient turn and select the desired hold time. This function rotates the patient approximately 20° right, center then approximately 20° left pausing at each position for the set hold time. Pressing the button multiple times will cycle through the hold time settings and off.

## Pulsation / Alternating Pressure (AP) Therapy (optional configuration)



**Pulsation / AP Therapy Button** - Press to adjust intensity of pulsation therapy. Pressing the button multiple times will cycle through low pulsation, medium pulsation, high pulsation, alternating pressure settings and off.



**Pulsation / AP Cycle Time Button** - Press to select the pulsation cycle time. The AP cycle time will be automatically set to 10 minutes when the AP button is pressed. It can be adjusted to another setting as desired. Cycle times are selectable in 5, 10 and 15 minute increments. Pressing the button multiple times will cycle through 5, 10 and 15 minute settings. One of the Pulsation / AP settings must be selected before cycle time can be set.

# PATIENT PLACEMENT / TRANSFER

It is recommended that all chapters of this manual be reviewed prior to product use. Carefully read the **Contraindications, Risks and Precautions** and **Safety Information** sections in the **Introduction** chapter of this manual prior to placing a patient on the *Citadel* Patient Therapy System.

## Preparation for Patient Placement / Transfer

1. Lock caster brakes on frame.
2. Evaluate foot extension, extend frame and mattress if necessary.
3. Press and hold the On / Off button for two seconds on main control panel to activate air supply to the unit.
4. Level patient surface. Press Firm Mattress button to inflate the mattress to a higher pressure, making the air mattress firmer, to facilitate patient positioning.
5. Configure unit as required (example: add pillows, blankets, lines, IV poles, other equipment, accessories, etc., as necessary).
6. Set initial air pressures using the control panel:
  - Press the button for Height / Weight presets to select the profile that most closely represents the patient being placed. Cushions will inflate to a preset air pressure based on the patient's height and weight.



*Presets are provided for reference only. Individual patient needs should be assessed and the pressure settings should be adjusted to meet each patient's individual needs.*

## Patient Placement

1. Adjust the pressure settings in each section of the mattress to meet individual patient needs. Pressure is adjusted by pressing the Pressure Zone Adjustment buttons. Press up arrows to increase pressure and down arrows to decrease pressure.

## Patient Transfer from the *Citadel* Patient Therapy System

1. Level patient surface.
2. Adjust height of patient surface to same level as surface to which patient is being transferred.
3. Ensure brakes on both units are locked.
4. Lower side rails.
5. Transfer patient, following all applicable safety rules and institution protocols.



6. If patient will not be returning, press and hold the On / Off button for two seconds to turn off the control unit. When the unit turns off, you will hear the valves open and the mattress will deflate.

## **Patient Transport**

1. Press the Patient Transport Button to inflate the Air Mattress slightly above the set pressures to prepare for patient transport.
2. You may unplug the power cord from the wall outlet and wrap the cord onto the cord hook at the head end of the unit once the bed has emitted an audible tone and the transport indicator is solid green.
3. If necessary, place patient's IV therapy onto IV poles that may be placed into sockets located on all four corners of the unit.
4. Verify side rails are raised and locked.
5. Unlock brakes.
6. Transport patient following all applicable safety rules and institution protocols.
7. Plug power cord into wall outlet immediately following completion of patient transport.
8. Once bed is plugged into the wall outlet, press and hold the On / Off button on the mattress control unit for two seconds to turn on the control unit.

# NURSING CARE

It is recommended that all chapters of this manual be reviewed prior to product use. Carefully read the **Contraindications, Risks and Precautions** and **Safety Information** sections of the **Introduction** chapter of this manual prior to performing nursing care for a patient on the *Citadel* Patient Therapy System.

## CPR

CPR is initiated from the bed frame Attendant Control Panel or backrest release handle. When CPR is activated the mattress control unit will shut off and the mattress will deflate. The bed frame will begin to articulate, and after a two second delay the mattress will deflate. The user must continue to press the CPR button until the bed frame is in the proper position. Press and hold the power button for two seconds to reactivate system. Refer to *Citadel* Bed Frame System Instructions for Use for details.

## Alarms



Once an alarm condition is detected, the typical delay in sounding the audible and visual alarm signals is no more than one second.









- An amber-colored alarm indicator will light up when an alarm condition is present. Typically, the alarm indicator is accompanied by another indicator to indicate why an alarm occurred.








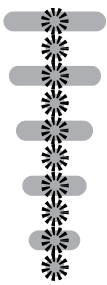

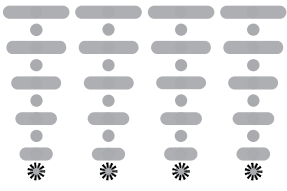







Press and hold the **Alarm Silence / Clear Button** for three seconds to silence the alarm tone for ten minutes. If the condition causing the alarm is not corrected within ten minutes the alarm tone will resume.



For optimal recognition of alarm conditions, user should be positioned at the end of the bed.

Active Alarm Icons			Alarm Description
 solid amber	 solid amber	 flashing green	Side rail lowered during patient turn (nurse assist).
 solid amber	 solid amber	 flashing green	Side rail lowered during continuous patient turn.

Active Alarm Icons			Alarm Description
 solid amber	 solid amber	 flashing green	Head angle raised above 30° during patient turn (nurse assist).
 solid amber	 solid amber	 flashing green	Head angle raised above 30° during continuous patient turn.
 solid amber	 flashing green		Mattress cannot reach target pressure after 10 minutes. Tighten air connectors See page 15.
 solid amber	 flashing green		Mattress base cannot reach pressure after five minutes. Tighten air connectors See page 15.
 solid amber	 flashing green		Turn bladder cannot reach pressure in patient turn (nurse assist) after five minutes. Tighten air connectors See page 15.
 solid amber	 flashing green		Turn bladder cannot reach pressure in continuous patient turn after five minutes. Tighten air connectors See page 15.
 solid amber			CPR switch cable disconnected. Reconnect CPR switch cable.

## Audible Tone Indicators

Name	Indication	Tone Description
Power On	System is powered on	One short, high tone (~1600 Hz)
Function Complete	Function has achieved intended state	Two short, low tones (~700 Hz)
Disabled Function	User attempts to activate a function that is not allowed due to an alarm state or an existing unsafe condition	One short, low tone (~800 Hz)
Time-Out	Function has been left in a state longer than allowed	One short, high tone (~1400 Hz)
Alarm	Alarm condition has been identified	Two tones. One short medium tone (~1000 Hz) and one short, low tone (~750 Hz), repeating every 15 seconds.
Gateway Communication Cable	Becomes unplugged	Two tones. One short medium tone (~1000 Hz) and one short, low tone (~750 Hz), repeating every 15 seconds.

## Patient Bathing

1. Adjust height and level patient surface to facilitate ease of bathing.
2. Lower side rails (on caregiver's side).
3. Bathe patient following institution protocols. Avoid spilling fluids on frame control panels.



**Fluids remaining on controls can cause corrosion, which may cause components to fail or operate erratically, possibly producing potential hazards for patient and staff.**

4. Raise and lock side rails.
5. Adjust patient surface for patient comfort.

# CARE AND CLEANING

## General Recommendations

The following are the ArjoHuntleigh-recommended cleaning and infection control procedures for the *Citadel* Patient Therapy System.

It is recommended that all sections of this guide be reviewed prior to product use. Carefully read the **Risks and Precautions** and **Safety Information** sections in the **Introduction** chapter prior to performing cleaning procedures on the *Citadel* Patient Therapy System.



*To prevent cross contamination or equipment damage, ArjoHuntleigh recommends that the Citadel Patient Therapy System be cleaned during use and between patients according to the instructions below. Local protocols and regulations / procedures for blood borne pathogens may be used provided the manufacturer's instructions are followed.*



*Always disconnect the Citadel Bed Frame System from wall outlet before cleaning. Failure do so could result in equipment damage and / or electric shock.*

## Decontamination



*Do not allow the mains plug or power cord to get wet.*

*Do not use abrasive compounds or pads, or phenol-based disinfectants.*

*Do not use jet stream cleaning or wash tunnels.*

The air mattress control unit should be cleaned and disinfected weekly, and before a new patient is placed on the bed.

The bed should be cleaned and disinfected weekly, and before a new patient is placed on the bed.

### Cleaning

1. Remove the mattress and all accessories from the bed.
2. The head and foot boards and mattress platform sheets should be removed from the bed for cleaning.
3. Wearing suitable protective clothing, clean all surfaces with a disposable cloth moistened in hand hot water and a neutral detergent.
4. Start by cleaning the upper sections of the bed and work along all horizontal surfaces. Work methodically towards the lower sections of the bed and clean the wheels last. Take extra care to clean areas that may trap dust or dirt.
5. Wipe over with a new disposable cloth moistened with clean water and dry with disposable paper towels.

6. Allow the cleaned parts to dry before replacing the mattress.

### Disinfecting

1. After cleaning the bed as described above, wipe all surfaces with sodium dichloroisocyanurate (NaDCC) at a concentration of 1,000 parts per million (0.1%) of available chlorine.
2. In case of pooling body fluids, e.g. blood, the concentration of NaDCC should be increased to 10,000 parts per million (1%) of available chlorine.
3. Wipe over with a new disposable cloth moistened with clean water and dry with disposable paper towels.



*Iodophor type disinfectants (e.g. Betadine, etc.) are not recommended and will stain fabric.*

### Cleaning the *Citadel* Patient Therapy System While in Use

4. If possible, remove the patient from the bed prior to cleaning. Daily care and cleaning consists of wiping down all surfaces and side rails (as needed) during patient bathing.
5. Follow care and cleaning instructions for the specific patient support surface in use.
6. Unplug the *Citadel* Patient Therapy System from wall outlet.
7. Inspect the power cord for any signs of wear or damage. The *Citadel* Patient Therapy System should not be operated with a worn or damaged power cord. Contact ArjoHuntleigh if damage is found.
8. Using a cloth dipped in warm soapy water or approved hospital disinfectant (diluted according to manufacturer's instructions), wipe the surfaces of the *Citadel* Patient Therapy System. Rinse with plain water.



*Do not allow fluid to penetrate the *Citadel* Patient Therapy System control panels.*

9. Allow all components to dry completely before returning to use.
10. Inspect all parts of the *Citadel* Patient Therapy System for damage prior to returning the unit to use. Contact ArjoHuntleigh for service or replacement.
11. Plug bed into wall outlet and adjust settings.
12. With bed plugged into the wall outlet, press and hold the On / Off button for two seconds to turn on the control unit.

## Cleaning and Maintenance Between Patients

1. Unplug the *Citadel* Bed Frame System from wall outlet. Using a cloth dipped in warm soapy water or approved hospital disinfectant (diluted according to manufacturer's instructions), wipe the surfaces of the *Citadel* Patient Therapy System. Rinse with plain water.
2. Allow all components to dry completely before returning to use.



*Do not allow fluid to penetrate the Citadel Patient Therapy System control panels.*

3. Inspect all parts of the *Citadel* Patient Therapy System for damage prior to returning to use. Contact ArjoHuntleigh for service or replacement.



**When not in service, bed frame must remain plugged in to the wall outlet to maintain battery charge.**

## Care And Cleaning Mattress Cover Fabrics







ArjoHuntleigh has introduced the next generation of medical fabrics. These fabrics are designed specifically to improve product performance and add customer value through enhanced durability.

The cover specification and recommended cleaning parameters are described below. For cleaning components other than mattress covers, refer to the relevant product Instructions for Use or other product labeling. Cleaning processes should be adapted to comply with the local or national guidelines (Decontamination of Medical Devices) which may apply within the Healthcare Facility or the country of use. If you are uncertain, you should seek advice from you local Infection Control Specialist.

The *Citadel* Patient Therapy System is made of Reliant IS<sup>2</sup> material and can be laundered and / or disinfected according to the Cover Specification table.

Reliant IS<sup>2</sup>: Polyurethane coated polyester fabric with enhanced durability.

Cover Specification	
Feature	Reliant IS <sup>2</sup>
Removable Cover	Yes
Moisture Vapor Permeable	Low
Low Friction	No
Water Resistant / Repellent	Yes
Polyurethane coating includes an anti-fungal agent to control microbial deterioration of fabric	Yes
Fire Retardant*	BS 7175: 0,1 & 5
2-Way Stretch	Yes
Recommended Wash Temperatures	60°C (140°F) 15 min.
Maximum Wash Temperatures	Max 95°C (203°F) 15 min.
Recommended Drying Temperatures	60°C (140°F) or air dry
Maximum Drying Temperatures	Max 80°C (176°F)
Wipedown Chemicals**	Chlorine at strength of 1000 ppm or Alcohol at 70% concentration; no phenol; ensure product is dry before storage.

Cleaning Symbols					
 Max 95 15 Min.	Recommended wash temperature: 15 min. at 60°C (140°F). Maximum wash temperature: 15 min. at 95°C (203°F)	 Max 80	Tumble dry at 60°C (140°F) Maximum drying temperature 80°C (176°F)	 1000 ppm NaOCl NaDCC	Use solution diluted to 1000 ppm of Available Chlorine
			Do not use Phenol-based cleaning		
	Wipe all surfaces with cleaning solution, then wipe with a cloth moistened with water and dry thoroughly		Do not iron		

\* For additional flammability testing standards, refer to individual product law tags

\*\* Chlorine concentrations may vary from 250 ppm to 10,000 ppm depending on local policy and contamination status. If an alternative disinfectant is selected from the wide variety available, ArjoHuntleigh recommended that suitability for use is confirmed with the chemical supplier prior to use.



# OPERATING INSTRUCTIONS

It is recommended that all chapters of this manual be reviewed prior to product use. Carefully read the **Contraindications, Risks and Precautions** and **Safety Information** sections in the **Introduction** chapter of this manual prior to placing a patient on the *Citadel* Patient Therapy System.

## Normal Therapy Mode

Control of set pressures for patient support (head, shoulders, body, feet and lower cushions), without other therapeutic features activated.

## Nurse Assist Functions

**Seat Deflate** - lowers pressure in the seat section of mattress to zero. When the pressure reaches 50% of the previous pressure setting, an audible tone will sound. The audible tone will continue to sound every five minutes as a reminder that seat deflate is active. Press seat deflate button again to cancel; this function will not automatically time out.

**Head Deflate** - lowers pressure in the head section of mattress to zero. When the pressure reaches 50% of the previous pressure setting, an audible tone will sound. The audible tone will continue to sound every five minutes as a reminder that head deflate is active. Press head deflate button again to cancel; this function will not automatically time out.



**Head deflate and seat deflate functions may not be active at the same time.**

**Firm Mattress** - increases pressure to aid in lateral transfer. Pressing this button will inflate all cushions to maximum pressure to provide a firm surface. When the system reaches maximum pressure, an audible tone will sound. The audible tone will continue to sound every five minutes as a reminder that firm mattress is active. If this function is not manually cancelled by pressing the firm mattress button, it will automatically time out in 30 minutes and return to previously selected pressure settings.





**Audible reminders will sound every five minutes to indicate that head, seat deflate or firm mattress mode are active.**



**Turning - CAUTION:** *Prior to engaging any mattress turn feature, make sure that bed frame has side rails and that all side rails are fully engaged in their full upright and locked position. Do not activate the turning feature on any mattress system when patient restraints are in use.*


**Patient Turn (nurse assist)** - inflates bladders under the mattress to provide patient right or left rotation of approximately 20°. An audible tone will sound when full rotation has been achieved. In order to activate this function, all side rails must be up and the fowler angle must be less than 30°. If a side rail is lowered in the direction of the patient turn or the fowler angle is increased to above 30°, this function will be cancelled. Press the Patient Center button to cancel patient turn; this function will not automatically time out.


 **Patient Turn is not available when fowler angle is above 30° or any side rail is down. It is recommended that turning only be initiated when bed is level and thigh and calf sections are down.**

 **The actual angle of rotation achieved by a patient is dependent on many factors including: patient weight, patient weight distributions, pressure settings and patient positioning on the mattress surface. 20° is the target turn angle, but will not be achieved by all patients based on the variables mentioned above.**

## Therapies

**Continuous Patient Turn** - continuously rotates the patient 20° right, center, then 20° left pausing at each position for the set hold time. In order to activate this function, all side rails must be up and the fowler angle must be less than 30°. If any side rail is lowered or the fowler angle is increased to above 30°, this function will be cancelled. Press the Continuous Patient Turn button to cancel therapy; this function will not automatically time out.





 **Rotation therapies are not available when fowler angle is above 30° or any side rail is down. It is recommended that turning only be initiated when bed is level and thigh and calf sections are down.**

 **The actual angle of rotation achieved by a patient is dependent on many factors including: patient weight, patient weight distributions, pressure settings and patient positioning on the mattress surface. 20° is the target turn angle, but will not be achieved by all patients based on the variables mentioned above.**

## Alternating Pressure / Pulsation

**Alternating Pressure** - fills every second cell of a cushion to a target pressure while the others are deflated to near zero pressure. This state is held for a period of time and then the deflated cells are inflated to a selected pressure. Once achieved, the other cells are deflated to near zero and this state is held for a period of time. The total time taken to complete this is one cycle.

**Pulsation** - fills every second cushion to a target pressure while the others are deflated to a slightly lower pressure. Once this is achieved, it is held for a period of time and then the deflated cells are inflated to the target pressure. Once achieved, the other cells are deflated to a slightly lower pressure and this is held for a period of time. The total time taken to complete this is one cycle. Cycle times and intensity are selectable by the user. Intensity settings for each therapy are described below:

Symbol	Therapy description	Pressure Target in Increased Bladders. (% of Set Pressure)	Pressure Target in Decreased Bladders. (% of Set Pressure)
	Alternating Pressure	↑ 125%	↓ 0%
	High Pulsation	↑ 148%	↓ 42%
	Medium Pulsation	↑ 128%	↓ 55%
	Low Pulsation	↑ 115%	↓ 75%

### Power Off *Citadel* Patient Therapy System

1. Press and hold the On / Off button on the mattress control unit for two seconds to turn off the control unit. When the unit turns off, you will hear the valves open and the mattress will deflate.
2. Unplug the power cord from the wall outlet.
3. Wrap the power cord around the cord hook on the head end of the frame.

## WARRANTY AND SERVICE

ArjoHuntleigh standard terms and conditions apply to all sales; a copy is available upon request. Standard terms and conditions contain full details of warranty terms and do not limit the statutory rights of the consumer.

For service, maintenance and any questions regarding this product, please contact your local ArjoHuntleigh office or approved distributor. A list of ArjoHuntleigh offices can be found at the back of this manual in the Questions and Information section.

Have the model number and serial number of the equipment available when contacting ArjoHuntleigh regarding service, spare parts or accessories.

# ELECTROMAGNETIC COMPABILITY (EMC)

Product has been tested for compliance with current regulatory standards regarding its capacity to block EMI (electromagnetic interference) from external sources.

Some procedures can help reduce electromagnetic interferences:

- Use only ArjoHuntleigh cables and spare parts to avoid increased emissions or decreased immunity which can compromise the correct functioning of the equipment.
- Ensure that other devices in patient-monitoring and/or life-support areas comply to accepted emissions standards.



*Wireless communications equipment such as wireless computer network devices, mobile phones, cordless telephones and their base stations, walkie-talkies, etc. can affect this equipment and should be kept at least 1.5 m away from the equipment.*


Intended Environment: Professional Healthcare Facility Environment.


Exceptions: HF Surgical Equipment and the RF Shielded room of an ME SYSTEM for magnetic resonance imaging.



*Use of this equipment adjacent to or stacked with other equipment should be avoided because it could result in improper operation. If such use is necessary, this equipment and the other equipment should be observed to verify that they are operating normally.*

Guidance and manufacturer's declaration – electromagnetic emission		
Emission test	Compliance	Guidance
RF emissions CISPR 11	Group 1	This equipment uses RF energy only for its internal functions. Therefore its RF emissions are very low and are not likely to cause any interference in nearby electronic equipment.
RF emissions CISPR 11	Class A	
Harmonic emissions IEC 61000-3-2	Class A	
Voltage fluctuations / flicker emissions IEC 61000-3-3	Complies	This equipment is suitable for use in all establishments other than domestic and those directly connected to the public low-voltage power supply network that supplies buildings used for domestic purposes.

Guidance and manufacturer's declaration – electromagnetic immunity			
Immunity test	IEC 60601-1-2 test level	Compliance level	Electromagnetic environment - guidance
Electrostatic discharge (ESD) IEC 61000-4-2	±2kV, ±4kV, ±8kV, ±15kV air ±8kV contact	±2kV, ±4kV, ±8kV, ±15kV air ±8kV contact	Floors should be wood, concrete or ceramic tile. If floors are covered with synthetic material the relative humidity level should be at least 30%
Conducted disturbances induced by RF fields EN 61000-4-6	3V in 0,15 MHz to 80 MHz 6V in ISM and amateur radio bands between 0,15 MHz and 80 MHz 80% AM at 1 kHz	3V in 0,15 MHz to 80 MHz 6V in ISM and amateur radio bands between 0,15 MHz and 80 MHz 80% AM at 1 kHz	Portable and mobile RF communications equipment should be used no closer to any part of the product, including cables, than 1.0m, if the transmitter's output power rating exceeds 1W <sup>a</sup> . Field strengths from fixed RF transmitters, as determined by an electromagnetic site survey, should be less than the compliance level in each frequency range <sup>b</sup> . Interference may occur in the vicinity of equipment marked with this symbol: 
Radiated RF electromagnetic field EN 61000-4-3	Professional Healthcare environment 3 V/m 80 MHz to 2,7 GHz 80% AM at 1 kHz	Professional Healthcare environment 3 V/m 80 MHz to 2,7 GHz 80% AM at 1 kHz	
Proximity fields from RF wireless communications equipment EN 61000-4-3	385 MHz - 27 V/m 450 MHz - 28 V/m 710, 745, 780 MHz - 9V/m 810, 870, 930 MHz - 28 V/m 1720, 1845, 1970, 2450 MHz - 28 V/m 5240,5500, 5785 MHz - 9V/m	385 MHz - 27 V/m 450 MHz - 28 V/m 710, 745, 780 MHz - 9V/m 810, 870, 930 MHz - 28 V/m 1720, 1845, 1970, 2450 MHz - 28 V/m 5240,5500, 5785 MHz - 9V/m	
Electrical fast transient/burst EN 61000-4-4	±1kV SIP/SOP ports ±2kV AC port 100kHz repetition frequency	±1kV SIP/SOP ports ±2kV AC port 100kHz repetition frequency	Mains power supply should be that of a typical commercial or hospital environment.
Power frequency Magnetic field EN 61000-4-8	30A/m 50 Hz or 60 Hz	30A/m 50 Hz	Power frequency magnetic fields should be at levels characteristic of a typical location in a typical commercial or hospital environment.

Guidance and manufacturer's declaration – electromagnetic immunity			
Immunity test	IEC 60601-1-2 test level	Compliance level	Electromagnetic environment - guidance
Electrostatic discharge (ESD) IEC 61000-4-2	±2kV, ±4kV, ±8kV, ±15kV air ±8kV contact	±2kV, ±4kV, ±8kV, ±15kV air ±8kV contact	Floors should be wood, concrete or ceramic tile. If floors are covered with synthetic material the relative humidity level should be at least 30%
Surge IEC 61000-4-5	±0,5kV ±1kV; ±2 kV, AC Mains, Line to Ground ±0,5kV ±1kV, AC Mains, Line to Line	±0,5kV ±1kV; ±2 kV, AC Mains, Line to Ground ±0,5kV ±1kV, AC Mains, Line to Line	
Voltage dips, short interruptions and voltage variations on power supply input lines IEC 61000-4-11	0% UT; 0,5 cycle At 0°, 45°, 90°, 135°, 180°, 225°, 270° and 315°  0% UT; 1 cycle and 70% UT; 25/30 cycles Single phase: at 0°  0% UT; 250/300 cycle	0% UT; 0,5 cycle At 0°, 45°, 90°, 135°, 180°, 225°, 270° and 315°  0% UT; 1 cycle and 70% UT; 25/30 cycles Single phase: at 0°  0% UT; 250/300 cycle	
 <p><math>U_T</math> is the a.c. mains voltage prior to the application of the test level</p>			
<p><sup>a</sup> Field strengths from fixed transmitters, such as base stations for radio (cellular/cordless) telephones and land mobile radios, amateur radio, AM and FM radio broadcast and TV broadcast cannot be predicted theoretically with accuracy. To assess the electromagnetic environment due to fixed RF transmitters, an electromagnetic site survey should be considered. If the measured field strength in the location in which the product is used exceeds the applicable RF compliance level above, the product should be observed to verify normal operation. If abnormal performance is observed, additional measures may be necessary.</p> <p><sup>b</sup> Over the frequency range 150 kHz to 80 MHz, field strengths should be less than 1 V/m.</p>			

# TROUBLESHOOTING



Contact ArjoHuntleigh if you are unable to correct a symptom by performing the suggested action listed in the table below.

Symptom	Check	Action
Mattress Does Not Reach Target Pressure	Check hose elbow connections under CPR valve for leaks	Press hose elbow connections firmly into CPR valve
	Check for leaking mattress cushion	Replace mattress cushion
	Check for leaking turning bladders	Replace turning bladder
	Check internal tubing for leaks	Repair leaking tubing
	Check for missing or damaged O-rings on mattress air connector ports	Replace O-rings
	Check to ensure CPR valve for leaks	Ensure CPR valve is fully closed Open CPR valve by pulling CPR handle and then close CPR valve by unplugging bed from AC Mains and then plugging it back in to AC Mains.
	Check hose connectors on mattress control unit	Correct leaking hose on mattress control unit
Mattress Control Unit Will Not Power Up	Check that AC power connector from the Bed Frame is plugged into the back of the Air Mattress Control Unit.	Ensure AC Power Cable from frame is connected to Air Mattress Control Unit.
	Check for Blown fuse in mattress control unit	Check and replace blown fuse on back of mattress control unit Check that bed frame power cord is plugged into AC outlet.
Mattress Control Unit makes frequent clicking sound.	Check to see if there are any bends in the tubing inside the mattress or in the expandable tubes on the Bed Frame.	Identify and replace leaking: Dump valve O-ring Cushion Turn bladder Tubing connector Tubing



# EXPLANATION OF SYMBOLS USED



Certified to UL Std. 60601-1



Temperature Low and High Limits



No Hooks



Protected against ingress of liquids



Important Operational Information



X-ray



Warning of possible hazard to system, patient or staff



Refer to Instructions for Use



Conforms with the Medical Device Directive (93/42/EEC) and has been subject to the conformity procedures laid down in the council directive



This product or its parts are designated for separate collection at an appropriate collection point. At the end of useful life, dispose of all waste according to local requirements, or contact your local ArjoHuntleigh representative for advice.



Maximum Patient Weight



Safe Working Load



Consult Instructions for Use



Alternating Current Power



Manufacturer



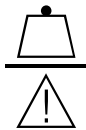
Shock Hazard



Date of Manufacture



Type B Applied Part



Safe Working Load



Reference Number



Serial Number



Recommended Wash Temperature

# EXPLANATION OF SYMBOLS USED CONTINUED



Tumble Dry



Wipe-down Only



No Phenol



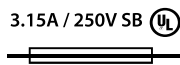
Chlorine Bleach



Do Not Iron



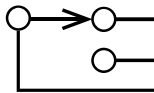
Protective earth (ground)



Fuse



Communications



CPR Switch



Head Cushion



Body Section



Seat Cushion



Leg Section



Lower Chamber



Turning Right



Turning L



Body Section A



Body Section B



Seat Section A



Seat Section B



Leg Section A



Leg Section B

# SPECIFICATIONS

Specifications subject to change without notice.

<b>General</b>	
Safe working load (mattress)	270 kg (595 lb)
Maximum patient weight	227 kg (500 lb)
Product weight (approx.)	Mattress control unit 25 kg (55 lb) Mattress 16 kg (35 lb)
Audible noise	<35dB
Operating conditions	
Temperature	14°C to 35°C (58°F to 95°F)
Relative humidity	20% to 80% non-condensing
Altitude	Up to 2000 m (6,562 ft)
<b>Electrical data</b>	
Power input	3A max at 115 VAC 60Hz 1.5A max at 230 VAC 50Hz
<b>In-bed length</b>	
Position 2 (standard)	202 cm (80 in)
Position 3 (Extended)	214 cm (84 in)
Overall width	89 cm (35 in)
<b>Environmental protection</b>	
Incorrect disposal of this equipment and its component parts may produce substances that are hazardous to the environment. To minimize these hazards, contact ArjoHuntleigh for information on correct disposal.	
<b>Transport and storage</b>	
Handle with care. Do not drop. Avoid shock or violent impact. This equipment should be stored in a clean, dry and well-ventilated area which meets the following conditions:	
Temperature	-15°C to 60°C (4°F to 140°F)
Relative humidity	non-condensing

Intentionally left blank

Intentionally left blank

Intentionally left blank

AUSTRALIA  
Arjo Australia Pty Ltd  
78, Forsyth Street  
O'Connor  
AU-6163 Western Australia  
Tel: +61 89337 4111  
Free: +1 800 072 040  
Fax: +61 89337 9077

BELGIQUE / BELGIË  
Arjo NV/SA  
Evenbroekveld 16  
BE-9420 ERPE-MERE  
Tél/Tel: +32 (0) 53 60 73 80  
Fax: +32 (0) 53 60 73 81  
E-mail: info.belgium@arjo.be

BRASIL  
Arjo Brazil  
Maquet do Brasil  
Rua Tenente Alberto Spicciati, 200  
Barra Funda, 01140-130  
SÃO PAULO, SP - BRASIL  
Fone: +55 (11) 2608-7400  
Fax: +55 (11) 2608-7410

CANADA  
Arjo Canada Inc.  
90 Matheson Boulevard West  
Suite 300  
CA-MISSISSAUGA, ON, L5R 3R3  
Tel/Tél: +1 905 238 7880  
Free: +1 800 665 4831 Institutional  
Free: +1 800 868 0441 Home Care  
Fax: +1 905 238 7881  
E-mail: info.canada@arjo.com

ČESKÁ REPUBLIKA  
ArjoHuntleigh s.r.o.  
Na Strži 1702/65  
140 00 Praha 4  
Tel: +420 549 254 252  
Fax: +420 541 213 550

DANMARK  
Arjo A/S  
Vassingerødvej 52  
DK-3540 LYNGE  
Tel: +45 49 13 84 86  
Fax: +45 49 13 84 87  
E-mail:  
dk\_kundeservice@arjo.com

DEUTSCHLAND  
Arjo GmbH  
Peter-Sander-Strasse 10  
DE-55252 MAINZ-KASTEL  
Tel: +49 (0) 6134 186 0  
Fax: +49 (0) 6134 186 160  
E-mail: info-de@arjo.com

ESPAÑA  
Arjo Ibérica S.L.  
Parque Empresarial Rivas Futura, C/  
Marie Curie 5  
Edificio Alfa Planta 6 oficina 6.1-.62  
ES-28521 Rivas Vacia, MADRID  
Tel: +34 93 583 11 20  
Fax: +34 93 583 11 22  
E-mail: info.es@arjo.com

FRANCE  
Arjo SAS  
2 Avenue Alcide de Gasperi  
CS 70133  
FR-59436 RONCQ CEDEX  
Tél: +33 (0) 3 20 28 13 13  
Fax: +33 (0) 3 20 28 13 14  
E-mail: info.france@arjo.com

HONG KONG  
ArjoHuntleigh (Hong Kong) Limited  
Room 411-414, 4/F,  
Manhattan Centre,  
8 Kwai Cheong Road,  
Kwai Chung, N.T.,  
HONG KONG  
Tel: +852 2960 7668  
Fax: +852 2960 1711

ITALIA  
Arjo Italia S.p.A.  
Via Giacomo Peroni 400-402  
IT-00131 ROMA  
Tel: +39 (0) 6 87426211  
Fax: +39 (0) 6 87426222  
E-mail: Italy.promo@arjo.com

MIDDLE EAST  
Huntleigh Middle East  
Office G005 - Nucleotide Complex,  
Biotechnology & Research Park,  
P.O.Box 214742, Dubai,  
United Arab Emirates  
Tel: +971 (0)4 447 0942  
E-mail: Info.ME@arjo.com

NEDERLAND  
Arjo BV  
Biezenwei 21  
4004 MB TIEL  
Postbus 6116  
4000 HC TIEL  
Tel: +31 (0) 344 64 08 00  
Fax: +31 (0) 344 64 08 85  
E-mail: info.nl@arjo.com

NEW ZEALAND  
Arjo Ltd  
34 Vestey Drive  
Mount Wellington  
NZ-AUCKLAND 1060  
Tel: +64 (0) 9 573 5344  
Free Call: 0800 000 151  
Fax: +64 (0) 9 573 5384  
E-mail: nz.info@Arjo.com

NORGE  
Arjo Norway AS  
Olaf Helsets vei 5  
N-0694 OSLO  
Tel: +47 22 08 00 50  
Faks: +47 22 08 00 51  
E-mail: no.kundeservice@arjo.com

ÖSTERREICH  
Arjo GmbH  
Lemböckgasse 49 / Stiege A / 4.OG  
A-1230 Wien  
Tel: +43 1 8 66 56  
Fax: +43 1 866 56 7000

POLSKA  
Arjo Polska Sp. z o.o.  
ul. Ks Piotra Wawrzyniaka 2  
PL-62-052 KOMORNIKI (Poznań)  
Tel: +48 61 662 15 50  
Fax: +48 61 662 15 90  
E-mail: arjo@arjo.com

PORTUGAL  
Arjo em Portugal  
MAQUET Portugal, Lda.  
(Distribuidor Exclusivo)  
Rua Poeta Bocage n.º 2 - 2G  
PT-1600-233 Lisboa  
Tel: +351 214 189 815  
Fax: +351 214 177 413  
E-mail: Portugal@arjo.com

SUISSE / SCHWEIZ  
Arjo AG  
Fabrikstrasse 8  
Postfach  
CH-4614 HÄGENDORF  
Tél/Tel: +41 (0) 61 337 97 77  
Fax: +41 (0) 61 311 97 42

SUOMI  
Arjo Scandinavia AB  
Riihitontuntie 7 C  
02200 Espoo  
Finland  
Puh: +358 9 6824 1260  
E-mail:  
Asiakaspalvelu.finland@arjo.com

SVERIGE  
Arjo International HQ  
Hans Michelsensgatan 10  
SE-211 20 MALMÖ  
Tel: +46 (0) 10 494 7760  
Fax: +46 (0) 10 494 7761  
E-mail: kundservice@arjo.com

UNITED KINGDOM  
Arjo UK and Ireland  
Houghton Hall Park  
Houghton Regis  
UK-DUNSTABLE LU5 5XF  
Tel: +44 (0) 1582 745 700  
Fax: +44 (0) 1582 745 745  
E-mail: sales.admin@arjo.com

USA  
Arjo Inc.  
2349 W Lake Street Suite 250  
US-Addison, IL 60101  
Tel: +1 630 307 2756  
Free: +1 800 323 1245 Institutional  
Free: +1 800 868 0441 Home Care  
Fax: +1 630 307 6195  
E-mail: us.info@arjo.com

Arjo Japan K.K.  
東京都港区東新橋二丁目11番3号第2  
小川ビル3階  
電話 : +81 (0)3-6435-6401

Address page - REV 21: 02/2018

---

**ARJOHUNTLEIGH**  
GETINGE GROUP



ArjoHuntleigh AB  
Hans Michelsensgatan 10  
211 20 Malmö, Sweden  
[www.arjohuntleigh.com](http://www.arjohuntleigh.com)

**CE**  
0086

---

ArjoHuntleigh is a world-leading provider of integrated products and solutions that improve the lives of patients and residents with reduced mobility. We help healthcare facilities deliver wellness and effective everyday care, early mobilisation, safe patient handling, venous thromboembolism prevention, pressure injury prevention, hygiene routines, bariatric care and diagnostics. With extensive knowledge and experience, we strive to improve efficiency and ensure a safer and dignified environment for caregivers and their patients.

---